

Biphasic Hydroformylation of Higher Olefins

Dr. Steven Dietz

AIChE Spring Meeting

Atlanta, GA

April 11, 2005

Hydroformylation

- **Largest commercial application of homogeneous catalysis**

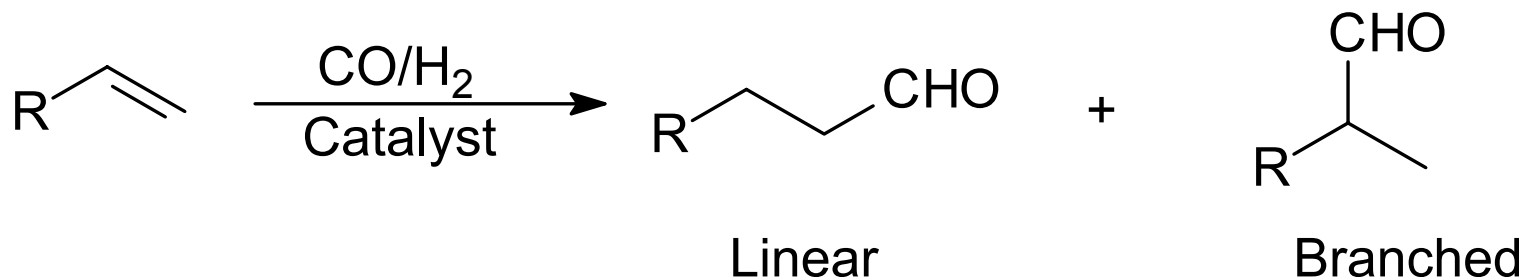

- **Worldwide production of aldehydes exceeds 7 million tons/year**
- **Higher aldehydes (>C₆) are important intermediates for solvents, detergents, surfactants, lubricants and plasticizers**

Aldehyde Production

- Rhodium and cobalt catalysts can be used
- Rhodium phosphine catalysts have replaced cobalt catalysts for lower aldehydes (<C₆) because of their higher activity and selectivity
- Because of the high cost of rhodium, catalyst losses have to be very low

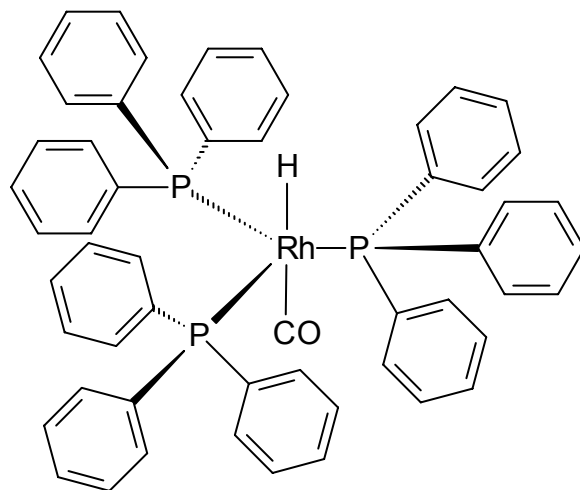

Single-Phase Homogeneous Hydroformylation (lower aldehydes)

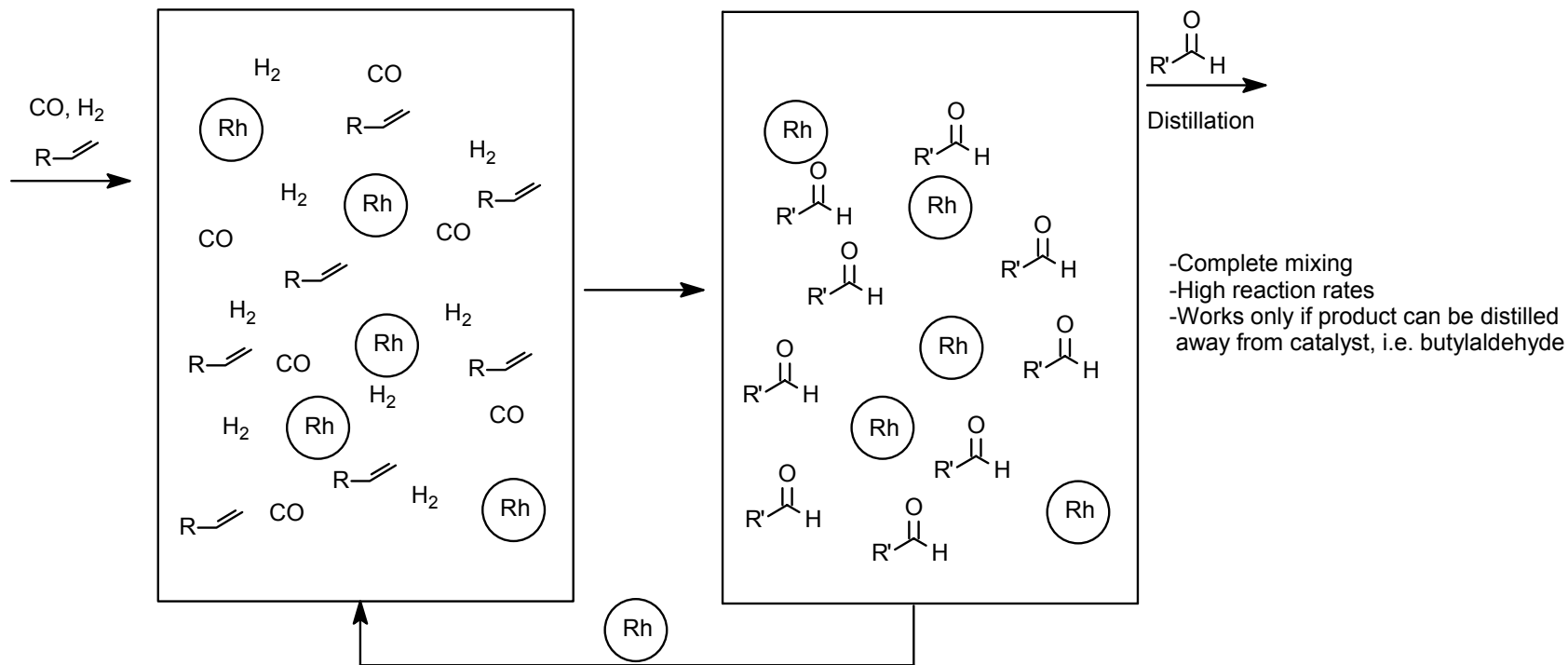

Higher Aldehydes

- **The higher boiling points of higher aldehydes result in catalyst decomposition**
- **Higher aldehydes are produced using less efficient cobalt catalyst because there is no effective means to separate the catalyst from the reaction mixture**

Biphasic Hydroformylation (Ruhrchemie-Rhône Poulenc)

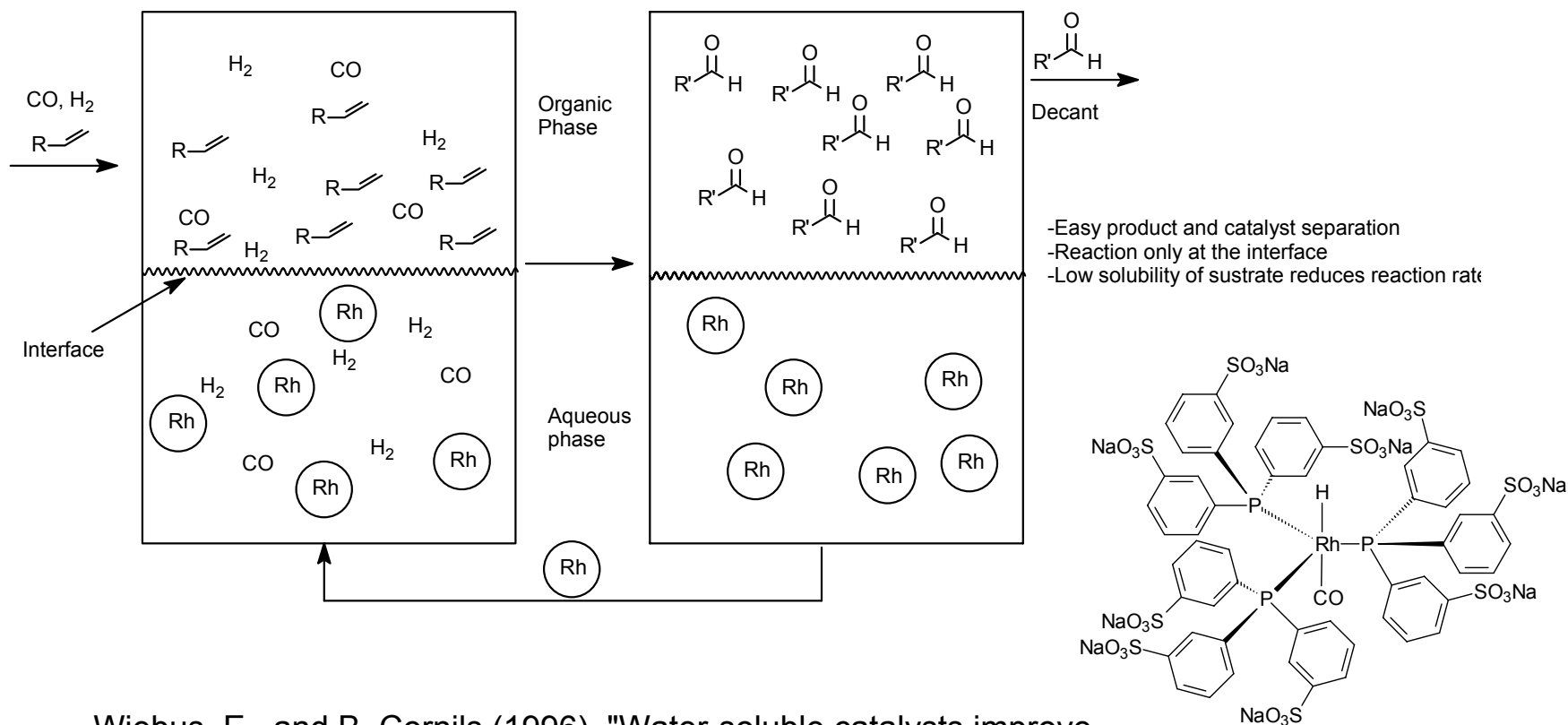

Wiebus, E., and B. Cornils (1996). "Water-soluble catalysts improve hydroformylation of olefins," *Organic Processing*, March 63-66.

Thermomorphic Hydroformylation

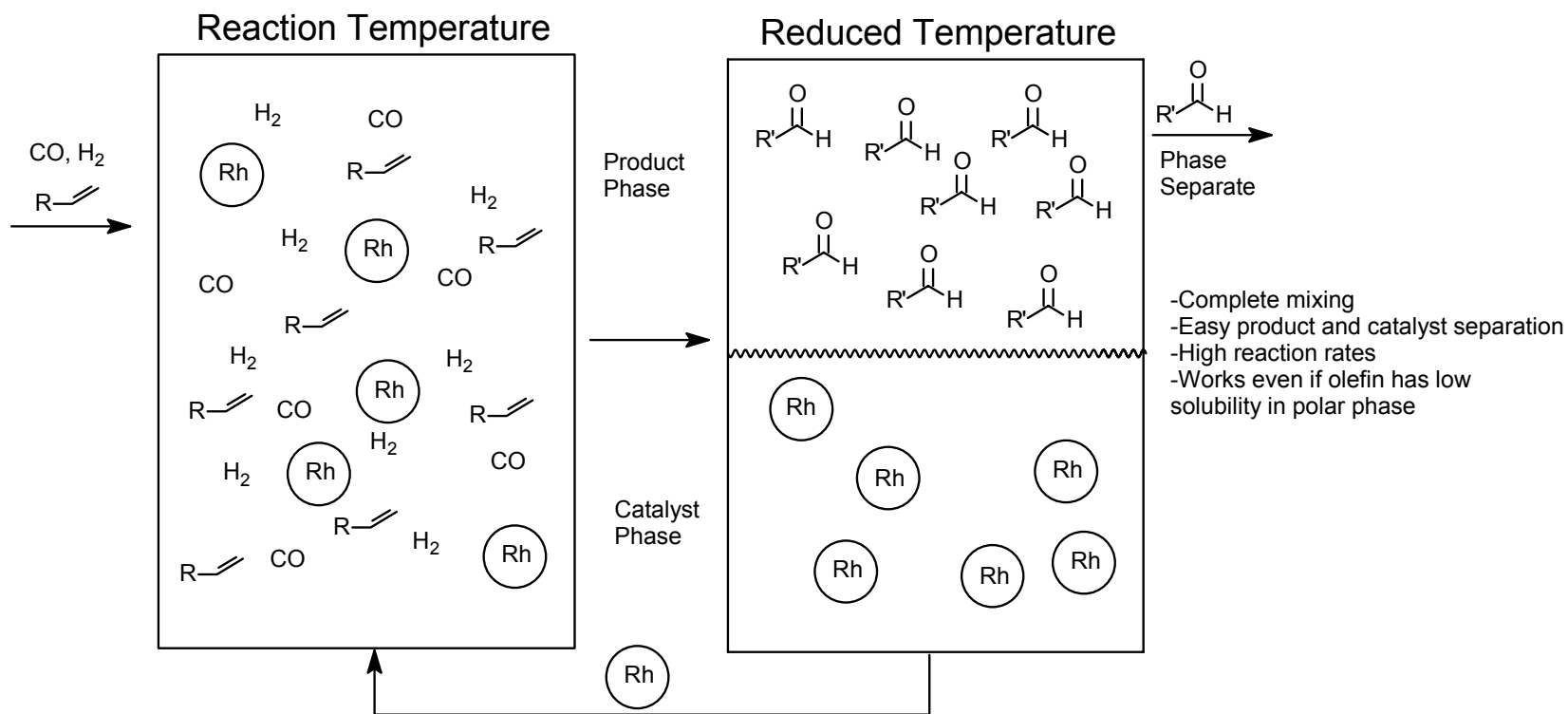

Fluorous Thermomorphic Hydroformylation

- Hydroformylation has been done using perfluoromethylcyclohexane/toluene thermomorphic solution with fluorinated phosphine ligands
- Catalyst: $\text{HRh}(\text{CO})\text{-}(\text{P}(\text{CH}_2\text{CH}_2(\text{CF}_2)_5\text{CF}_3)_3)_3$
- Problem is that fluorinated solvents and ligands are very expensive

Horváth, I.T., and J. Rábai (1994). "Facile Catalyst Separation Without Water: Fluorous Biphasic Hydroformylation of Olefins," *Science* 266, 72-75

Non-Fluorous Thermomorphic Solutions

- **Common solvent pairs that reversibly change from being biphasic to monophasic as a function of temperature**
 - Methanol/cyclohexane (49°C)
 - *n*-butanol/water (125°C)
- **TDA's approach is to use conventional solvents and ligands for thermomorphic hydroformylation**

Thermomorphing Catalyst Solution



25°C



70°C

Technical Barriers

- **Show that our catalyst system can produce higher aldehydes in a continuous reactor with:**
 - High selectivity (linear/branched ratio)
 - Reasonable rates
 - Long catalyst lifetime
 - Low rhodium loss
- **How issue will be addressed**
 - Built a bench-scale continuous reactor
 - Do process optimization and long-term testing

Bench-Scale Continuous Reactor



- Reactor body manufactured by Autoclave Engineers
- 300 ml volume
- Fitted with Magnedrive stirrer and Dispersimax™ impeller for improved gas dispersion in liquid
- Rated up to 4700 psig at 200°C, 3800 psig at 538°C
- Computer controlled (OptoControl software)

P&ID of Bench-Scale Continuous Reactor

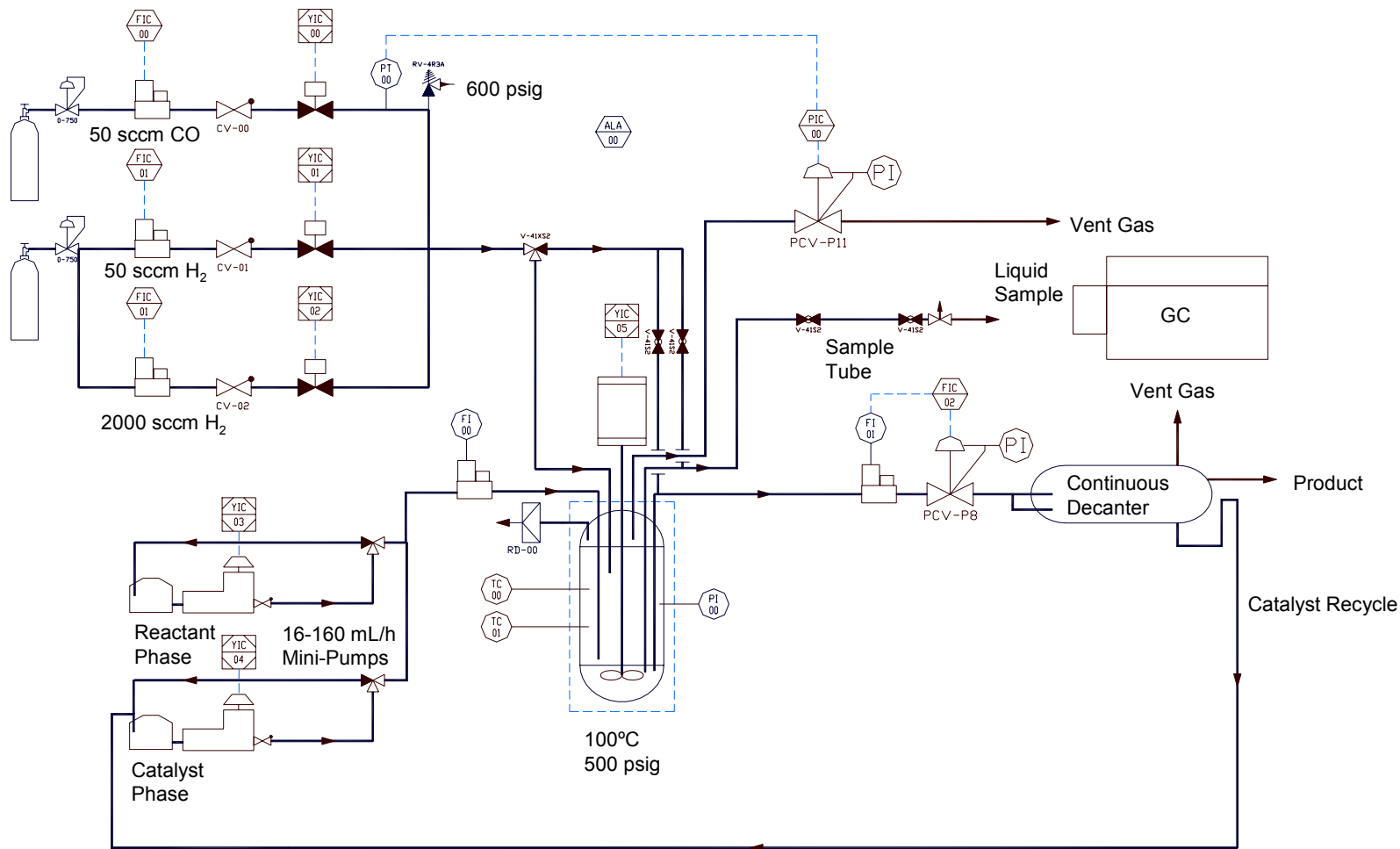

1-Octene Hydroformylation

- **Linear/branched ratio – 5:1**
- **1:1 - CO:H₂, total pressure 500 psi**
- **Temp. – 100°C**

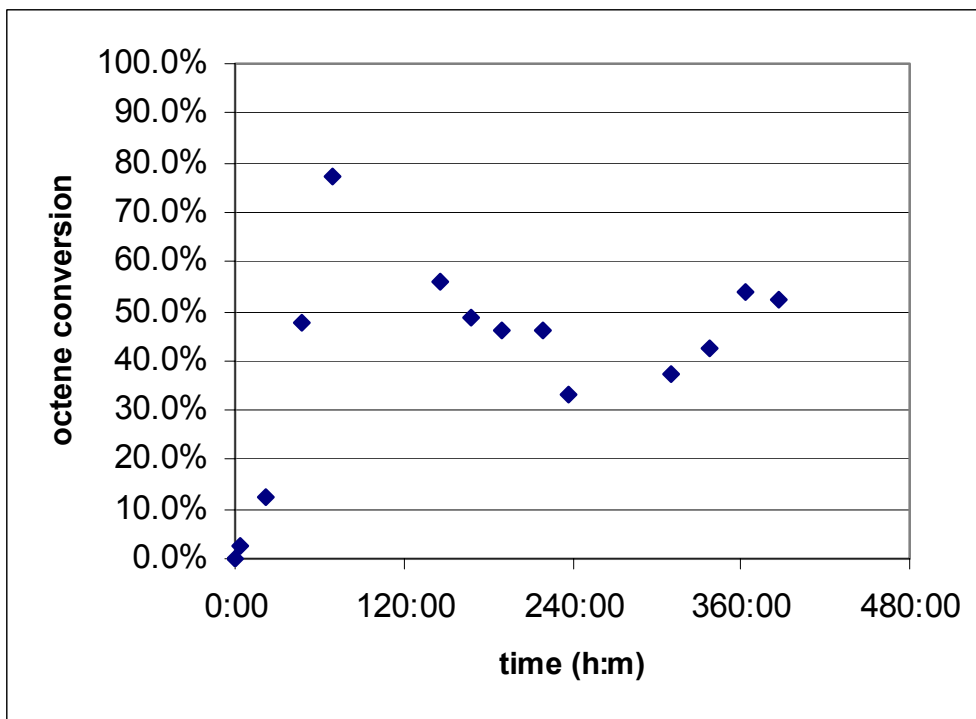

1-Dodecene Hydroformylation

- **Linear/branched ratio – 4:1**
- **1:1 - CO:H₂, total pressure 500 psi**
- **Temp. – 100°C**

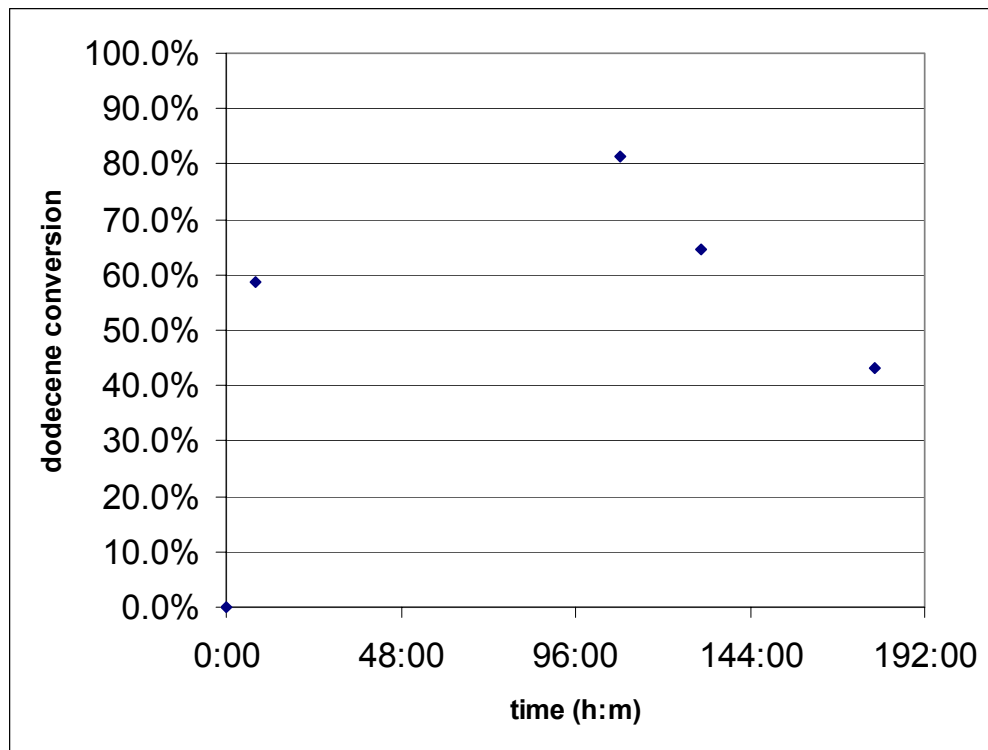

Catalyst Longevity

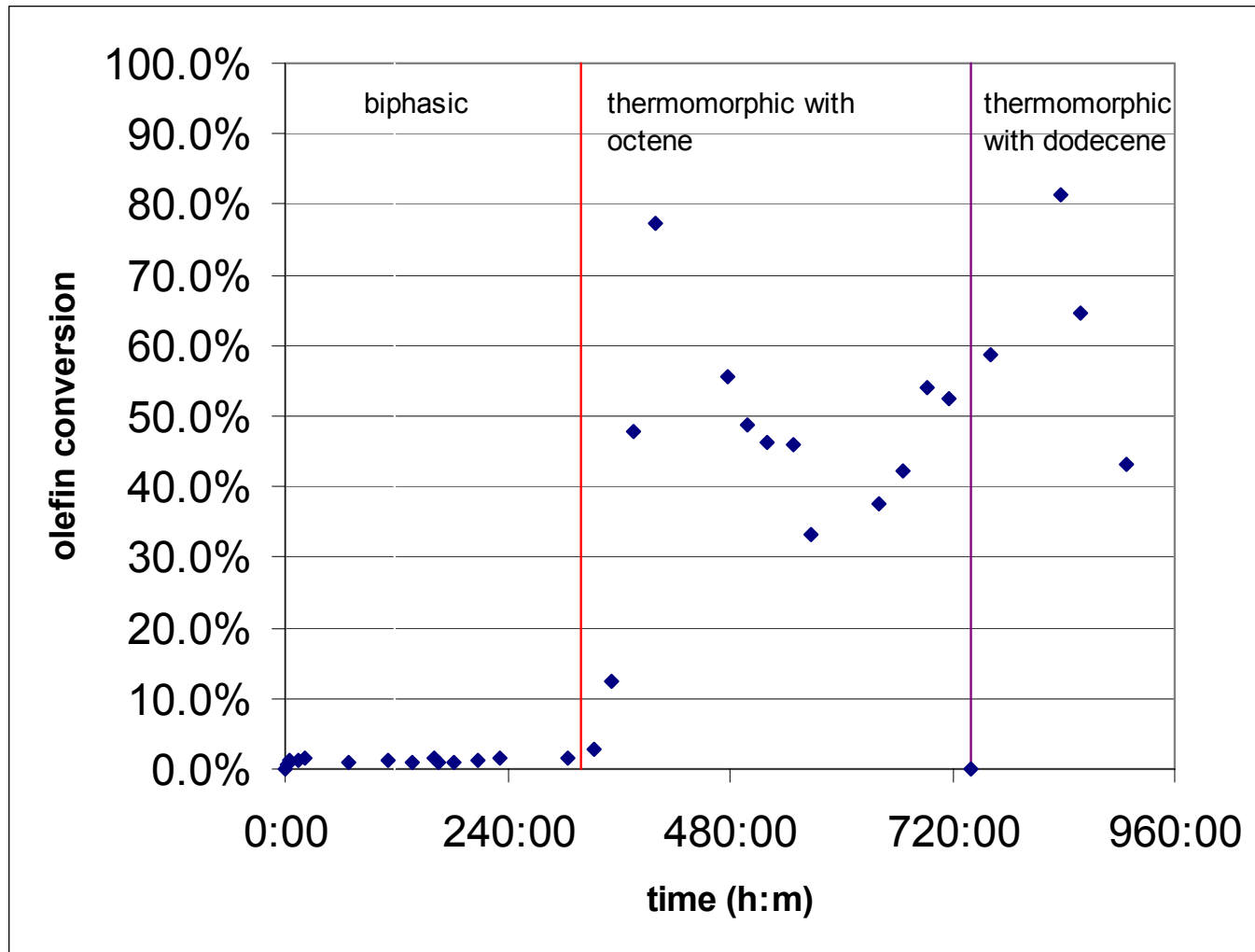

Summary

- **Successfully developed thermomorphic catalyst system for hydroformylation**
- **Built a continuous bench-scale reactor**
- **In the process of optimizing catalyst system in a continuous system and long-term catalyst durability testing**
- **From the results of our work we expect to convince potential commercial partners to license the technology**

Acknowledgement

- **This work is being funded by DOE SBIR Phase II project**
- **Contract: DE-FG03-01ER83307/A002**